

BUILDING RETROFITS: BREATHING NEW LIFE INTO EXISTING BUILDING STRUCTURES

CLIFFORD SCHWINGER



Clifford Schwinger

Clifford Schwinger, P.E. is Vice President and Quality Assurance Manager at Cagley Harman & Associates. Mr. Schwinger received his BSCE degree from Lehigh University and has been with Cagley, Harman & Associates for 20 years. He's on the AISC Manuals and Textbooks Committee.

Abstract

Steel building structures often undergo modifications to accommodate new uses and occupancies during their lifespan. This paper discusses methods and procedures used for analyzing and strengthening the framing in existing steel structures including: procedures for reviewing the load capacity of existing framing and connections; weldability issues related to welding to existing steel structures; and tips and techniques for strengthening existing beams, columns and connections.

Introduction

The modification of existing building structures to accommodate new uses presents structural engineers with a variety of interesting challenges. Engineers working on such projects must take on an investigative role to ascertain existing conditions, followed by an analysis phase to determine the load capacity. When additional load capacity is required of an existing structure, engineers have the option of either strengthening the existing framing or adding new framing to replace or supplement the existing. Most building codes require existing structures undergoing substantial modifications or a change of occupancy to be upgraded to meet current building code requirements.

Code Issues

Chapter 34 of the *2006 International Building Code* (International Code Council, 2006) stipulates the requirements for additions and modifications to existing structures. The main points related modifications or additions to existing structures are as follows:

1. Alterations or additions must comply with the requirements of the code for new construction. (Section 3403.1)
2. Additions or alterations to an existing structure shall not cause a stress increase of more than 5 percent in any existing member unless the member can resist the increased load in accordance with the requirements of the code for new structures. (Section 3403.2)
3. Existing members found to be unsound or structurally deficient shall be repaired so that they can support the required loads in accordance with the requirements of the code for new structures. (Section 3403.2)
4. Additions to existing buildings that are seismically independent from adjacent existing structures shall be designed in accordance to the code for new structures. (Upgrades to the lateral load resisting system of the independent existing structure are not required.) (Section 3403.2.3.1)
5. Where an addition is added to an existing structure and that addition is not seismically independent from the existing structure, then the lateral load resisting system of the entire structure shall be upgraded to conform to the requirements of the code for new construction unless all of the following conditions are met (Section 3403.2.3.1):
 - a. The new addition conforms to the requirements for new structures.
 - b. The addition does not increase seismic forces in any member in the existing structure by more than 10 percent unless that increased force can be supported in accordance with the requirements of the code for new construction.
 - c. The addition does not decrease the seismic force resisting strength in any existing member by more than 10 percent unless there is sufficient residual strength in those members to support the seismic forces in accordance with the requirements of the code for new construction.
6. Where alterations are made to an existing structure the existing lateral load resisting system need not be upgraded as long as the seismic forces in any element do not increase by more than 10 percent or as long as the strength of any existing member resisting seismic forces is not diminished by more than 5 percent. (Section 3403.2.3.2)

Assessing Existing Structures

The availability of existing structural drawings makes the task of engineering modifications to existing structures easier. Unfortunately these drawings are often not available. Architectural drawings for pre-1940 buildings often showed a substantial amount of accurate information related to the structural framing. Occasionally some original architectural drawings are available even when the structural drawings are gone. At a minimum, architectural drawings provide engineers a good starting point for determining column locations, floor-to-floor heights and an approximation of the loads for which the structure may have been designed. Dates on original drawings can give a clue as to what building code may have been in effect and what AISC Specification may have been used when the building was designed. Architectural plans showing floor layouts will give insight as to what design live loads may have been used.

A site visit should always be performed to inspect the structure – especially for structures more than 30 years old. These site visits are required to assess the condition of the structure and to obtain all measurements required to perform the necessary structural analysis.

Some key things to look for when assessing the existing condition of a structure are as follows:

1. Any damage to framing?
2. Any noticeable corrosion?
3. Any signs that modifications to the structure that may have been performed without engineering review?
4. Any unusual deflections in floor framing?
5. Any cracks in supported slabs?
6. Any signs of foundation settlement?
7. Any signs that new rooftop equipment, heavy hung piping loads, folding partitions, rigging, or other suspended loads that may have been added without structural engineering review.

The following information must be obtained:

1. Floor-to-floor heights
2. Floor slab thicknesses
3. Column bay dimensions
4. Spacing and configuration of all floor framing
5. Dimensions of all floor framing members
6. Connection details
7. Joist sizes and geometry (look for joist tags).

Review of existing conditions during the survey should also be performed to ascertain the constraints and limitations for gaining access to the existing framing for the purposes of installing supplemental framing and/or reinforcing to the existing framing. Such access constraints may dictate what type of structural reinforcement would be most appropriate.

A valuable resource available to structural engineers working with existing building structures is *AISC Steel Design Guide 15 – AISC Rehabilitation and Retrofit Guide* (Brockenbrough, 2002). This publication is available free to AISC members. Design Guide 15 lists section properties of all beam and column shapes produced since 1873, provides a summary of all allowable stresses published and beam and column design equations published in every AISC specification since 1923, lists grades and yield strengths of all structural steel produced since 1900 and provides tables listing the in chronological order the allowable stresses in bolts, rivets and welds throughout the twentieth century. Another valuable source of information is the “Structural Engineers’ Handbook” by Milo S. Ketchum (1924). This book provides a wealth of knowledge for those working on building structures constructed prior to 1930. Copies of this publication are frequently available from used book dealers on the internet.

Determining Load Capacity of Existing Structures

Knowing the yield strength of the steel used in the framing is essential for computing the load capacity. A good starting point for establishing the probable yield strength is provided in Table A. Testing should be performed to ascertain and verify the actual yield strength.

One technique for finding additional strength in existing steel framed structures is to test the steel to determine its actual yield strength, in hope of finding it to be of a higher value than was used in the original design.

Probable F_y of W shapes	
Year Constructed	F_y (ksi)
1900-1931	30
1932-1960	33
1960-2000	36
2000-Present	36/50

Table A. This table is a guide that lists the most probable yield strength for W shapes. Actual yield strength of existing framing members should be defined from existing drawings or verified by testing.

Mill certification tests for A36 steel were quite often 40 ksi or higher. Likewise, many tons of steel produced in the mid-eighties through mid-nineties had dual certification – that is, the steel met the requirements of both ASTM A36 and ASTM A572, Grade 50. While dual certified steel may have been designed as A36 material, the actual yield strength was at least 50 ksi. Taking advantage of the actual yield strength can provide a substantial increase in member capacity.

Another technique for finding more strength in existing structures is to analyze the framing using LRFD.

LRFD useable strength is approximately 1.5 times greater than ASD service level strength. If the average load factor is less than 1.5, then LRFD design will provide greater load carrying capacity than ASD via the relative lower required strength.

Per Chapter 2 of ASCE 7-05, the required strength for a member supporting only dead and live gravity loads is $1.2D+1.6L$.

When the live load is the same magnitude as the dead load ($D = L$), the average load factor is 1.4. In most steel buildings the design live load is usually close to or less than the dead load. For members such as girders and columns supporting large tributary areas of floor framing, live load reductions permitted by building codes will usually reduce the average load factor to a value lower than 1.4.

An average load factor of 1.4 yields a 7% decrease ($1 - (1.4/1.5) = 0.07$) in required strength versus a 1.5 average load factor, resulting in an effective 7% increase in load capacity using LRFD design.

For columns in multistory structures where full live load reductions can be taken, the ratio of dead load / live load can often be 2 or more. When $DL/LL=2$, the average load factor is 1.33. An average load factor of 1.33 yields a 11% decrease ($1 - (1.33/1.5) = 0.11$) in required strength versus a 1.5 average load factor, resulting in an effective 11% increase in load capacity using LRFD design.

To reiterate, the increased load capacity achievable using LRFD is not an increase in member strength per se – but is a reduction in the required strength relative to usable strength that's realized when the average load factor is less than 1.5. The Allowable Stress Design and the newer Allowable Strength Design methodologies provide a constant safety factor of 1.5 (safety factor = nominal strength / usable strength) for all load combinations. LRFD design provides a variable factor of safety that decreases as the ratio between dead load and live load increases. Accordingly, analysis of structures using LRFD design will result in more efficient design than ASD design when the average load factor is less than 1.5. When investigating the load carrying capacity of existing structures the economic advantages of using LRFD design can be substantial especially when additional load carrying capacity can be justified that can eliminate or minimize the need for reinforcing the existing framing.

Weldability Issues

An excellent resource available to structural engineers for issues related to welding to existing structures is the paper "Field Welding to Existing Structures" by David Ricker. This publication is available at no charge to AISC members via the AISC website. The following are several important points with regards to welding to existing structures:

1. If the original framing has welded connections, then welding to the steel is acceptable.
2. Don't weld to cast iron or wrought iron (Ricker, 1988).
3. Weldability is verified by mechanical and chemical testing (Ricker, 1988).
 - a. Mechanical testing measures ductility.
 - b. Chemical testing determines the "carbon equivalent" value – a value that is a measure of weldability.
 - c. Steel buildings constructed between 1900 and 1962 were most likely constructed using ASTM A7 or A9 steel. The ASTM A7 and A9 specifications placed no limits on carbon content and other elements that affect weldability (Garlich, 2000). Although A7 and A9 steel is generally weldable, it should be tested.

- d. Steel buildings constructed after 1962 were constructed with weldable steel (A36 and A572). Testing to verify the weldability of this steel is not necessary.

Increasing Flexural Strength Floor Framing Members

There are two options for reinforcing existing floors to support additional loads:

- Option #1: Add new framing to supplement the existing framing.
 Option #2: Reinforce the existing beams, girders and connections.

Provided that the floor slab has sufficient capacity to carry the loads, the easiest solution is usually that of reinforcing the existing beams and girders. Figure 1 shows several ways of reinforcing existing W shapes to increase their flexural strength. The easiest and most cost effective method for reinforcing these members is to weld rectangular HSS's to the bottom flanges (Figure 1(a)). The advantages of using HSS in this manner are as follows:

1. Easy down-hand welding when the HSS is wider than beam flange.
2. Only one piece of steel to handle.
3. Easy to obtain, fabricate, handle and install in long lengths. (Plates generally have to be cut and spliced.)
4. Installation of a single HSS to the bottom flange is less labor intensive than welding plates to the bottom of the top and bottom flanges.
5. The fabrication cost of HSS's is less than that of plates. (Narrow plates are usually cut from wider plates.)
6. HSS's provide a greater increase in moment of inertia per dollar than do top and bottom field welded flange plates.
7. Welding new steel to the underside of the top flanges of existing girders is very difficult where other members frame to sides of the girders.
8. The yield strength of rectangular HSS shapes is 42 ksi, compared to 36 ksi for A36 plate material.

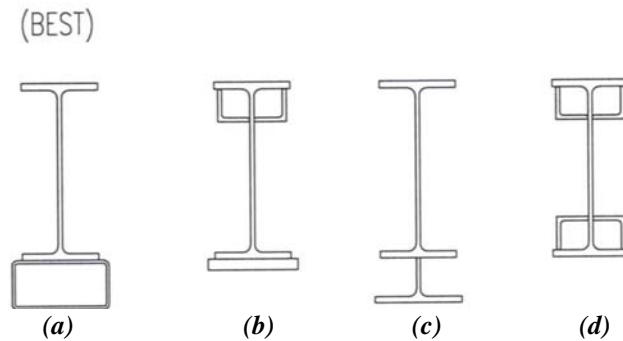

Figure 1.

Increasing axial load capacity of columns

Column axial load capacity is usually dictated by the column buckling limit state, of which slenderness kl/r is a variable. Column buckling in pinned-pinned “gravity load only” columns occurs at the mid-height of the column. Accordingly, when gravity columns require reinforcing to support additional loads, the reinforcing usually does not need to be installed continuous through the floor framing, provided that the factored load in the column through the floor is less than $0.90 \times F_y \times A_s$, and the column is braced in both directions by the floor framing.

Column reinforcing serves both to reduce slenderness (by increasing the radius of gyration of the section) as well as to reduce stress. Since column buckling in pinned-pinned gravity columns is a mid-height P^* phenomenon increasing column stiffness between the supports, not at the supports, is required to increase column capacity.

Figure 2(a) shows the most cost effective method for increasing the weak axis stiffness of a W shaped column. While the plates could be welded parallel and flush with the column flanges in Figure 2(b), this reinforcing configuration is not as efficient in reducing slenderness as it that shown in Figure 2(a). For either detail, the reinforcing plates can terminate several inches below the underside of the framing at the top of the column and several inches above the existing floor slab when the column is braced in both directions by the floor framing.

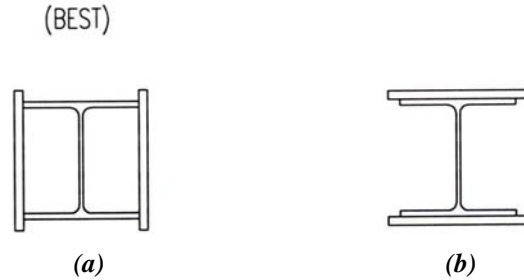
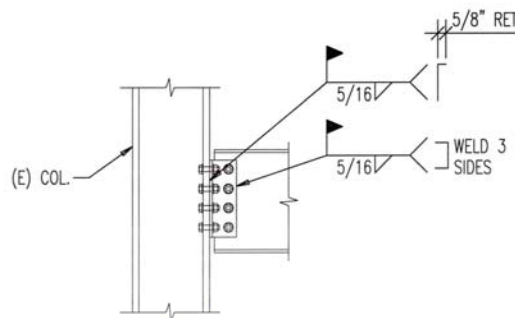

Figure 2.

Increasing Capacity of Connections

The capacities of existing connections must be determined when existing framing is modified or additional load capacity is sought. If additional load capacity is required, existing connections must either be reinforced or supplemented to provide the required capacity. The manner by which existing shear connections can be reinforced is limited only by the imagination of the engineer. Such reinforcing however usually consists of either adding welds to the existing connections (Figure 3), welding seat brackets to the ends of beams (Figure 4), replacing rivets or A307 bolts with high strength bolts (Figure 5), or a combination thereof.

AISC Design Guide 15 (Brockenbrough, 2002) provides historic data on design capacities that have been used for design of riveted, bolted and welded connections.



16 EXISTING CONNECTION REINFORCING

Figure 3.

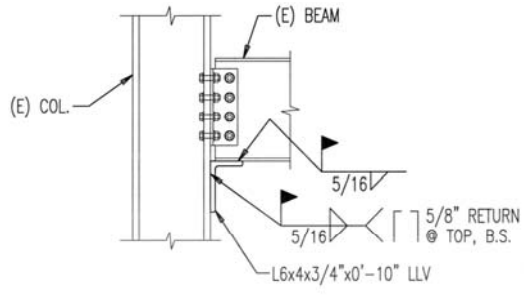

17 EXISTING CONNECTION REINFORCING

Figure 4.

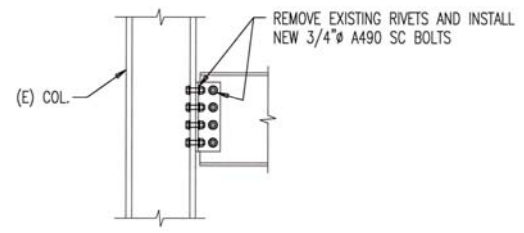

18 EXISTING CONNECTION REINFORCING

Figure 5.

Connecting New Framing To Existing Framing

As is the case with reinforcing existing connections there are many ways that new framing can be connected to existing framing.

If the existing steel is weldable, the best connection is most likely one that involves a welded connection to the existing structure. Welding new connection elements to existing steel is simpler and requires less precision as compared to the process of field drilling new holes through existing steel and field bolting connections to the steel.

Various details for connecting new framing to existing framing are shown in Figures 6 through 13.

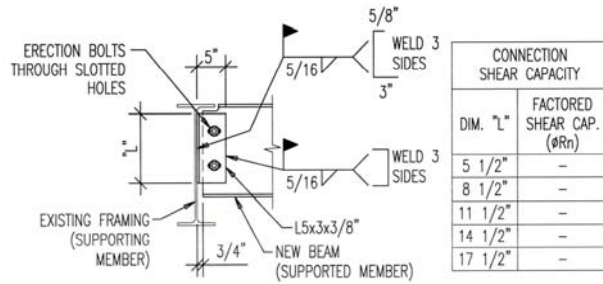

1 NEW BEAM TO EXISTING BEAM SINGLE ANGLE SHEAR CONNECTION

Figure 6.

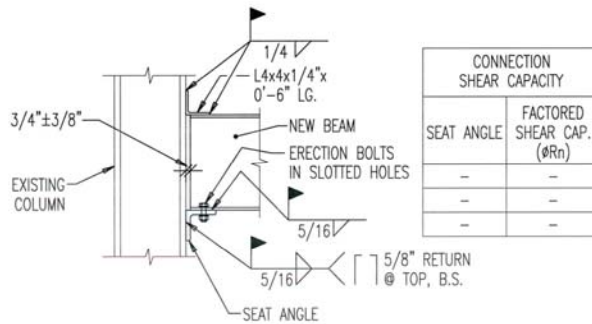

3 NEW BEAM TO EXISTING COLUMN SEAT ANGLE SHEAR CONNECTION

Figure 7.

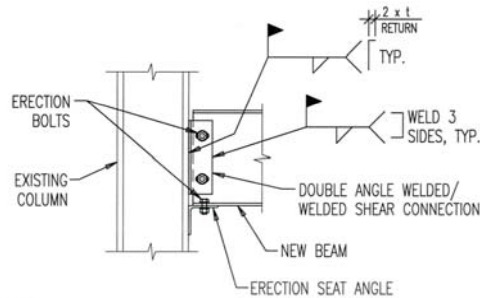

NOTES:

- REFER TO TABLE 10-3 IN THE THIRD EDITION AISC MANUAL OF STEEL CONSTRUCTION TO DETERMINE SHEAR CAPACITY OF WELDED/WELDED DOUBLE ANGLE SHEAR CONNECTIONS.
- CONNECTION TO COLUMN FLANGE SHOWN; CONNECTION TO COLUMN WEB SIMILAR.

4 NEW BEAM TO EXISTING COLUMN DOUBLE ANGLE SHEAR CONNECTION

Figure 8.

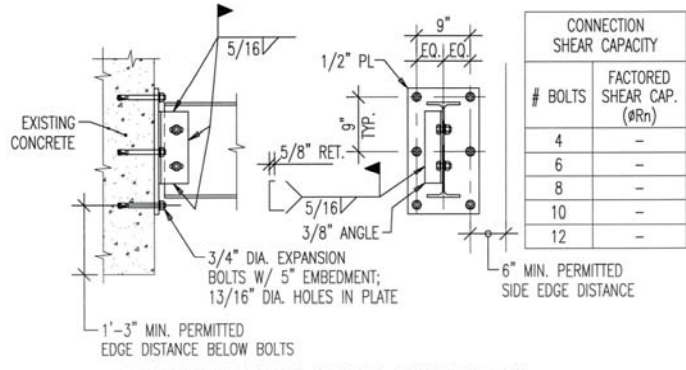

LOCATE REINFORCING STEEL IN EXISTING CONCRETE PRIOR TO DRILLING HOLES FOR EXPANSION BOLTS. ADJUST BOLT LOCATIONS TO AVOID INTERFERENCE WITH EXISTING REINFORCING STEEL.

5 NEW BEAM CONNECTION TO EXISTING CONCRETE

Figure 9.

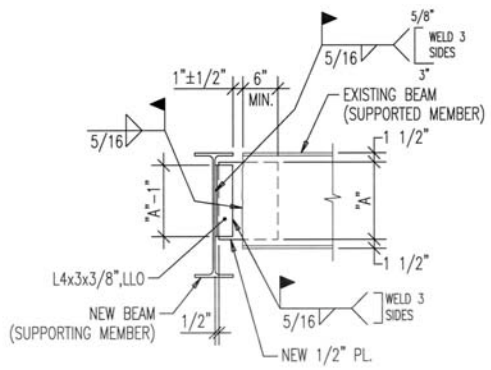

SHORE EXISTING BEAM BEFORE DISCONNECTING FROM EXISTING FRAMING; KEEP SHORES IN PLACE UNTIL NEW CONNECTION IS INSTALLED.

7 EXISTING BEAM CONNECTION TO NEW (SUPPORTING) BEAM

Figure 10.

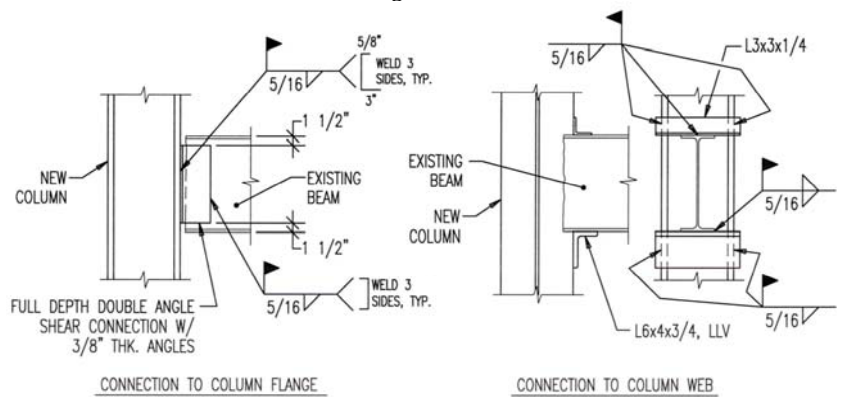

SHORE EXISTING BEAM BEFORE DISCONNECTING FROM EXISTING FRAMING; KEEP SHORES IN PLACE UNTIL NEW CONNECTION IS INSTALLED.

8 EXISTING BEAM CONNECTION TO NEW COLUMN

Figure 11.

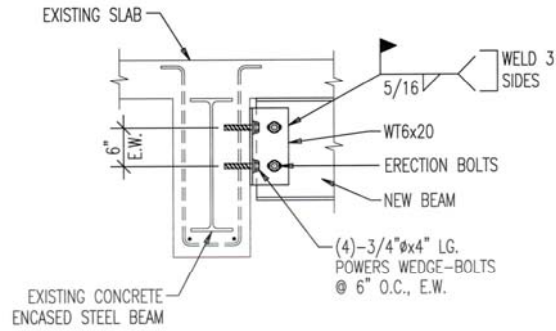

13 NEW BEAM CONNECTION TO EXISTING
CONCRETE ENCASED STEEL BEAM

Figure 12.

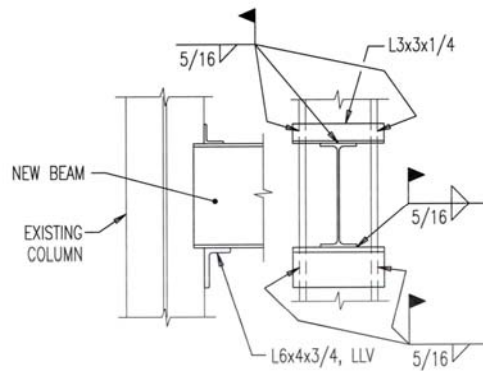

14 NEW BEAM CONNECTION TO EXISTING
COLUMN PERPENDICULAR TO WEB

Figure 13.

REFERENCES

1. Ricker, David T., *Field Welding to Existing Steel Structures*, AISC Engineering Journal, 1st Quarter 1988.
2. Garlich, Michael J., *Welding to Existing Structures*, Presented at North American Steel Construction Conference Las Vegas, February 24 and 25, 2000.
3. Brockenbrough, Roger L., *AISC Rehabilitation and Retrofit Guide – A Reference for Historic Shapes and Specifications, Steel Design Guide Series 15*, American Institute for Steel Construction, 2002.
4. Ketchum, Milo S., *Structural Engineers' Handbook, Data for the Design and Construction of Steel Bridges and Buildings*, McGraw-Hill Book Company, 1924.
5. *2006 International Building Code*, International Code Council, 2006, pp 541, 542.